

M A T R I X   P A C K A G I N G   M A C H I N E R Y

# G S E R I E S

Π   P   Σ   Φ   X   ϑ   Ϟ   Λ

# MATRIX

# X

**World's Fastest Vertical Machine  
in the smallest footprint to date!**

## **FEATURES:**

- Bag Width Range: 2" to 8"
- Bag Lengths: 3" to 15.5"
- OMRON PLC Platform with single point control
- Cantilever design
- 10.4 color HMI with InduSoft Web Studio HMI software

## **BENEFITS:**

- Speeds up to 300/minute
- Smallest machine footprint: ONLY 45" WIDE
- Ethernet connectivity

## **OPTIONS:**

- Gas flush
- Vacuum pull belts
- Bag accumulators
- Exclusive Matrix "Smartgate" high speed technology
- Washdown construction available soon
- Wider jaw capacity available soon



MATRIX         
  PACKAGING    
    MACHINERY INC.



**RUNNING WITH MATRIX**

650 Dekora Woods Blvd. Saukville, WI 53080  
Phone: (262) 268-8300 [www.matrixpm.com](http://www.matrixpm.com)

# MATRIX X

**FRONT VIEW**

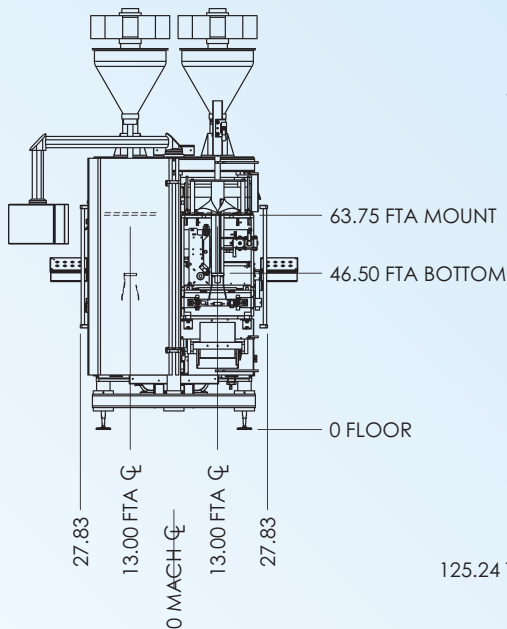

**TOP VIEW**

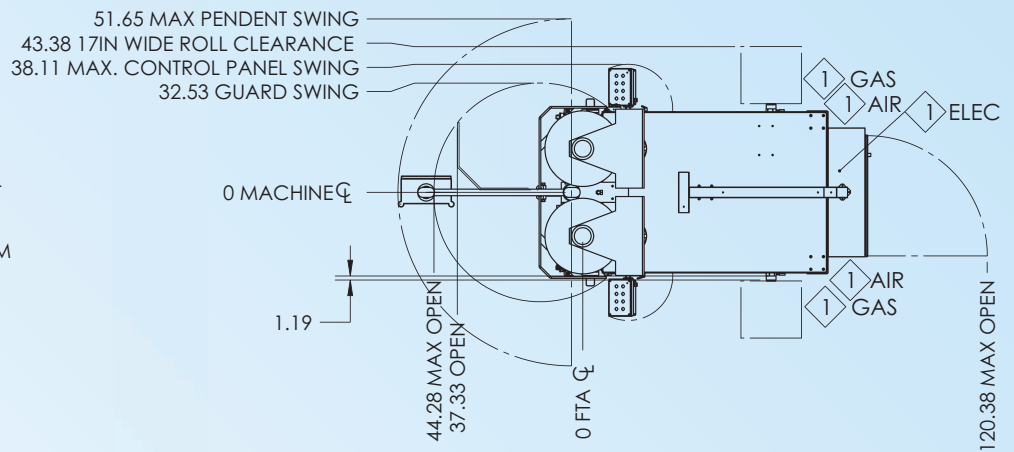

**SIDE VIEW**

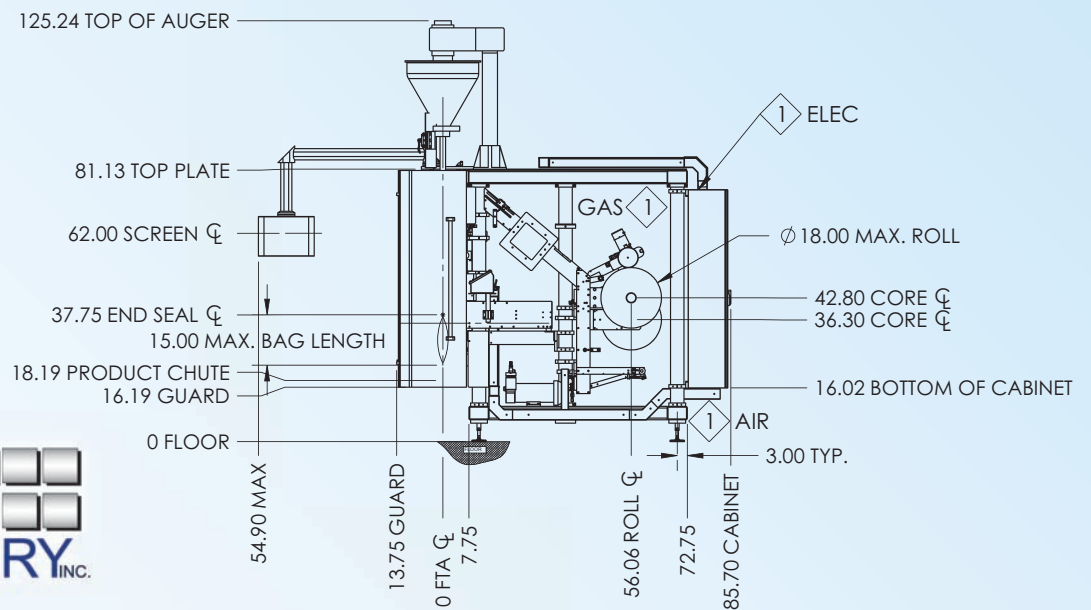

**MATRIX**  
**PACKAGING**  
**MACHINERY, INC.**



650 Dekora Woods Blvd. Saukville, WI 53080  
Phone: (262) 268-8300 [www.matrixpm.com](http://www.matrixpm.com)

***RUNNING WITH MATRIX***